



Aluminum Terminal Block Box



Aluminum Terminal Block Box

Specifications

Protection Level	Dust/Water proof: IP66/67, NEMA 4X/6
	Impact test: IK 08
Certification	CE, TUV, RoHS

Model No.	Outside size (including cover)		Number of poles	Terminal Layout
	W x L x H (Unit :mm)	W x L x H (Unit : inch)		
BC-AL-5PT	80 x 75 x 57	3.15 x 2.95 x 2.24	5	Stair
BC-AL-6P	80 x 75 x 57	3.15 x 2.95 x 2.24	6	Flat
BC-AL-9P	100 x 100 x 80	3.94 x 3.94 x 3.15	9	Flat
BC-AL-10PT	80 x 125 x 57	3.15 x 4.92 x 2.24	10	Stair
BC-AL-15PT	100 x 160 x 80	3.94 x 6.30 x 3.15	15	Stair
BC-AL-15P	100 x 160 x 80	3.94 x 6.30 x 3.15	15	Flat
BC-AL-20PT	120 x 220 x 80	4.72 x 8.66 x 3.15	20	Stair
BC-AL-20P	120 x 220 x 80	4.72 x 8.66 x 3.15	20	Flat
BC-AL-20PAS	150 x 132 x 90	5.90 x 5.19 x 3.54	20	2 Line Stair
BC-AL-20PA	160 x 160 x 90	6.30 x 6.30 x 3.54	20	2 Line Stair
BC-AL-20P2	160 x 160 x 90	6.30 x 6.30 x 3.54	20	2 Line Flat
BC-AL-25PT	160 x 260 x 90	6.30 x 10.24 x 3.54	25	Stair
BC-AL-30PA	180 x 180 x 100	7.09 x 7.09 x 3.94	30	2 Line Stair
BC-AL-30PAS	120 x 220 x 80	4.72 x 8.66 x 3.15	30	2 Line Stair
BC-AL-30P2	230 x 200 x 110	9.06 x 7.87 x 4.33	30	2 Line Flat
BC-AL-40PA	160 x 260 x 90	6.30 x 10.24 x 3.54	40	2 line Stair
BC-AL-40P2	160 x 260 x 90	6.30 x 10.24 x 3.54	40	2 Line Flat
BC-AL-45P3	230 x 200 x 110	9.06 x 7.87 x 4.33	45	3 Line Flat
BC-AL-50PA	160 x 260 x 90	6.30 x 10.24 x 3.54	50	2 Line Stair

Dimensions

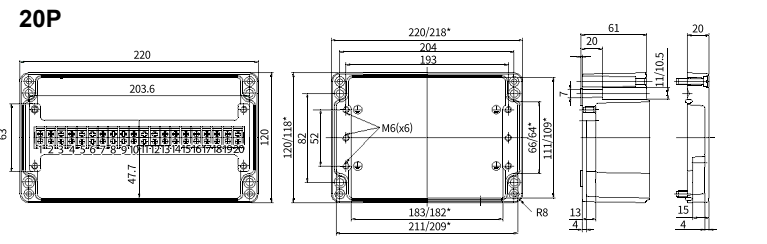
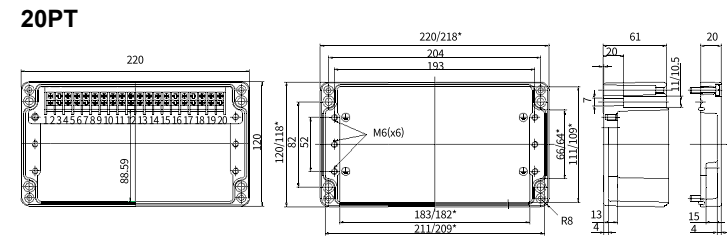
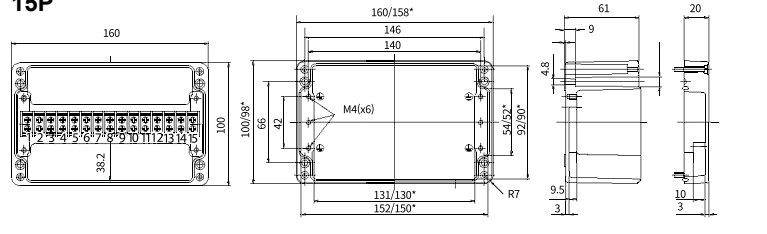
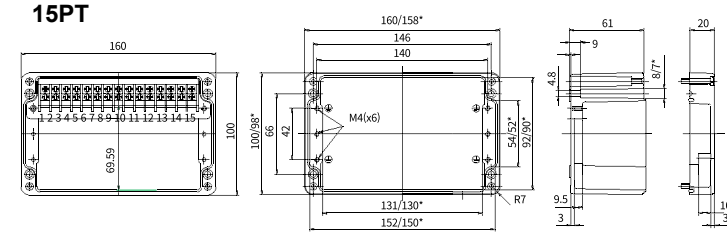
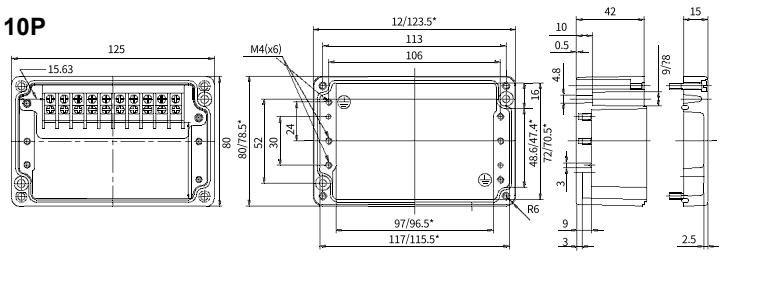
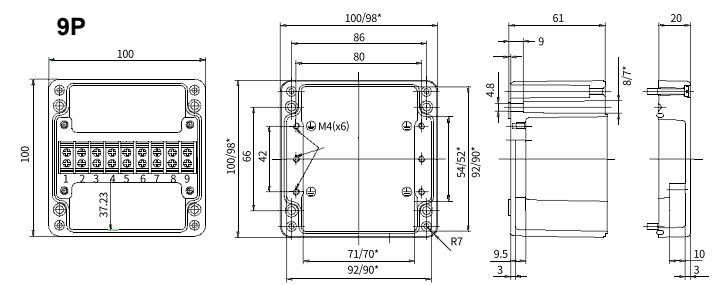
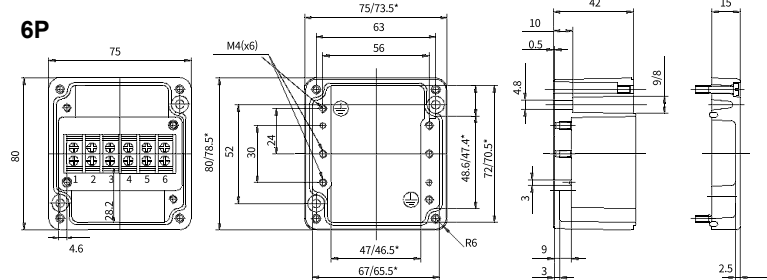
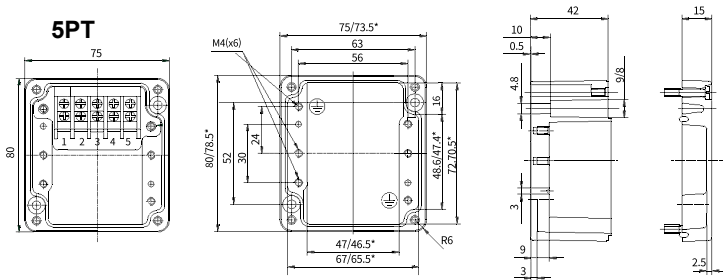

20PAS

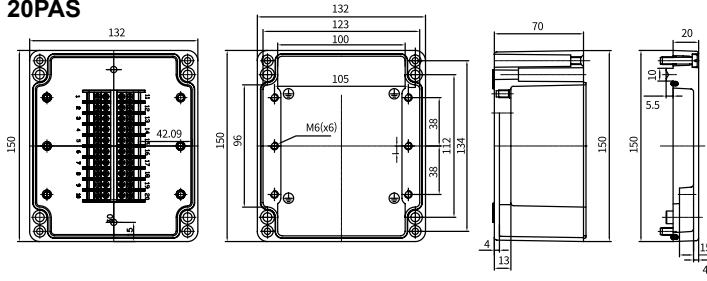

20PA

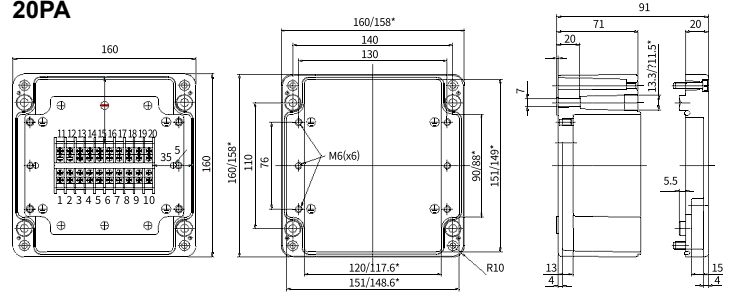

20P2

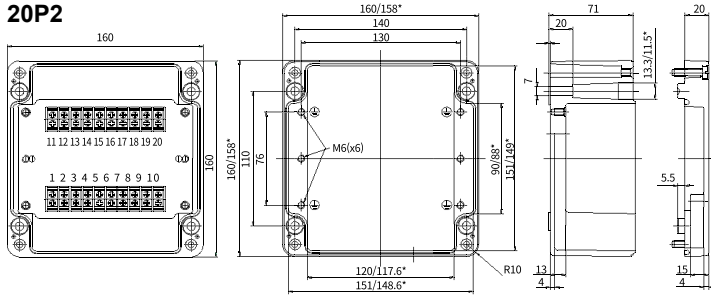

25PT

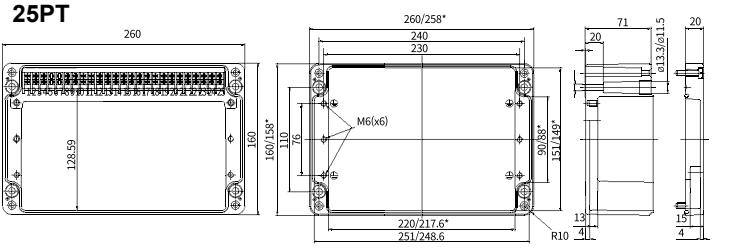

30PAS

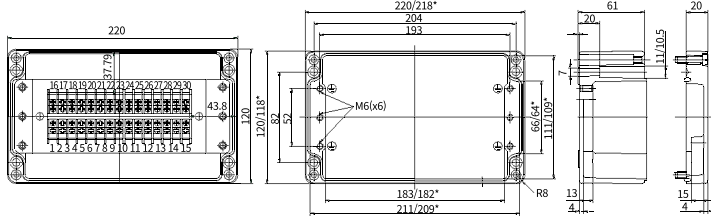

30PA

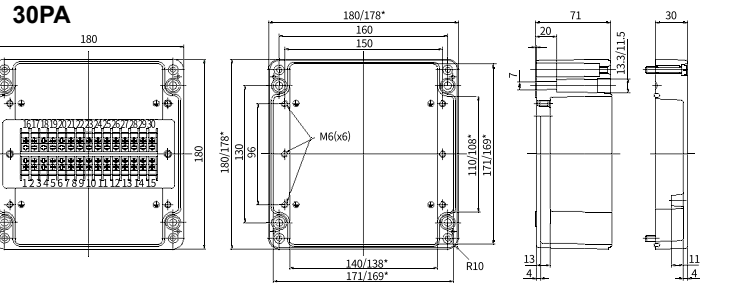

30P2

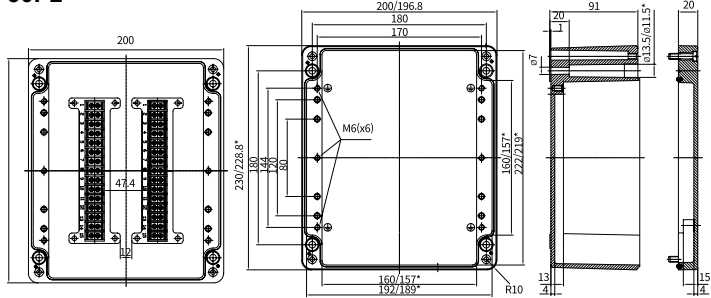

40PA

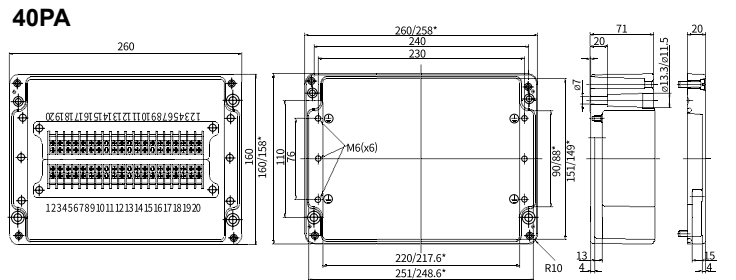

40P2

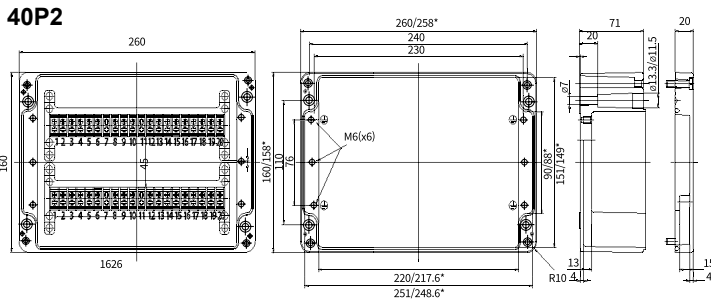

45P3

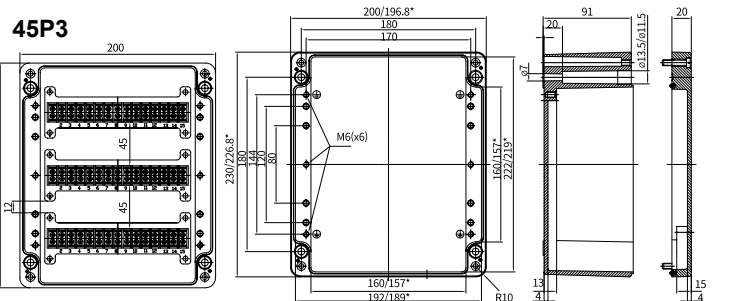

50PA

