

Fixed power wirewound resistors
aluminium housed 10 W to 250 W

FIXED POWER WIREWOUND RESISTORS ALUMINIUM HOUSED

FEATURES

Extruded aluminium housing provides superior heat conduction. Housing deep finned for maximum heat dissipation at natural or forced air convection.

Gold anodized finish for maximum resistance to environmental conditions. Special thermosetting compound with high thermal conductivity. Winding designed to give maximum core coverage and uniformity for even heat dissipation.

Core centerless ground for maximum winding uniformity. Marking at top surface for easy identification after mounting. Complete welded construction terminal to terminal.

RB Series



These resistors meet or exceed the requirements of MIL-PRF-18546 G specifications.

ELECTRICAL SPECIFICATIONS

- Ohmic values
Serie E24. For out of range or not standard ohmic values, consult ATE Technical Dept.

- Tolerance
Standard 5%. Available on request up to 1%.

- Temperature coefficient
±30 ppm R > 20 Ohm
±50 ppm 1 Ohm < R < 20 Ohm
±100 ppm 0.1 Ohm < R < 1 Ohm

- Dielectric strength
1500 Vac for RB10
2500 Vac for RB25 and RB50
3500 Vac for RB75, RB101 and RB150
4500 Vac for RB100 and RB250

- Insulation resistance
10000 MOhm minimum
1000 MOhm after moisture test

- Overload
5s at 5 times rated power

- Non inductive

Models of equivalent physical and electrical specifications are also available with non inductive Ayrton-Perry winding

MECHANICAL SPECIFICATIONS

- Terminal strength
10 lb. pull test; 3 Nm x RB100 and 4 Nm x RB250 max torque

- Solderability
Satisfactory when tested in accordance with method 208 of MIL-STD-202. The use of high temperature solder is recommended when resistors work near the maximum specified ratings

MATERIALS

- Core
Ceramic steatite or alumina centerless ground

- Resistive Element
Copper-nickel alloy or nickel-chrome alloy with specific temperature coefficient

- End caps
Stainless steel

- Encapsulant
High temperature thermosetting compound

- Housing
Aluminium with hard anodic finish

- Standard terminals
Copperweld RB10 to RB150
Stainless steel for RB100 and RB250

DERATING

ATE RB resistors have an operative temperature range from -55°C to +250°C. Derating is required for reduced chassis area and for high ambient temperature

Specifications

ATE Type	MIL-PRF-18546 G Type	Rated power (W)	Max power no heatsink (W)	Resistance range (Ohm)	Voltage limit (V)	Temp. rise with heatsink (W)	Weight (g)	Heatsink dimensions (cm x mm)
RB10	RE65	12	6	0.01-10K	265	5.1	6	415x1
RB25	RE70	25	12.5	0.01-18K	550	3	14	535x1
RB50	RE75	50	20	0.01-68K	1250	1.9	35	930x1.5
RB75	-	75	35	0.1-50K	1400	1.1	85	995x3
RB101	-	100	40	0.1-70K	1900	1	115	995x3
RB150	-	150	55	0.1-100K	2500	1	165	995x3
RB100	RE77	150	75	0.1-100K	1900	0.84	500	930x3
RB250	RE80	250	100	0.1-120K	2300	0.66	900	930x3

Fixed power wirewound resistors
aluminium housed 10 W to 250 W

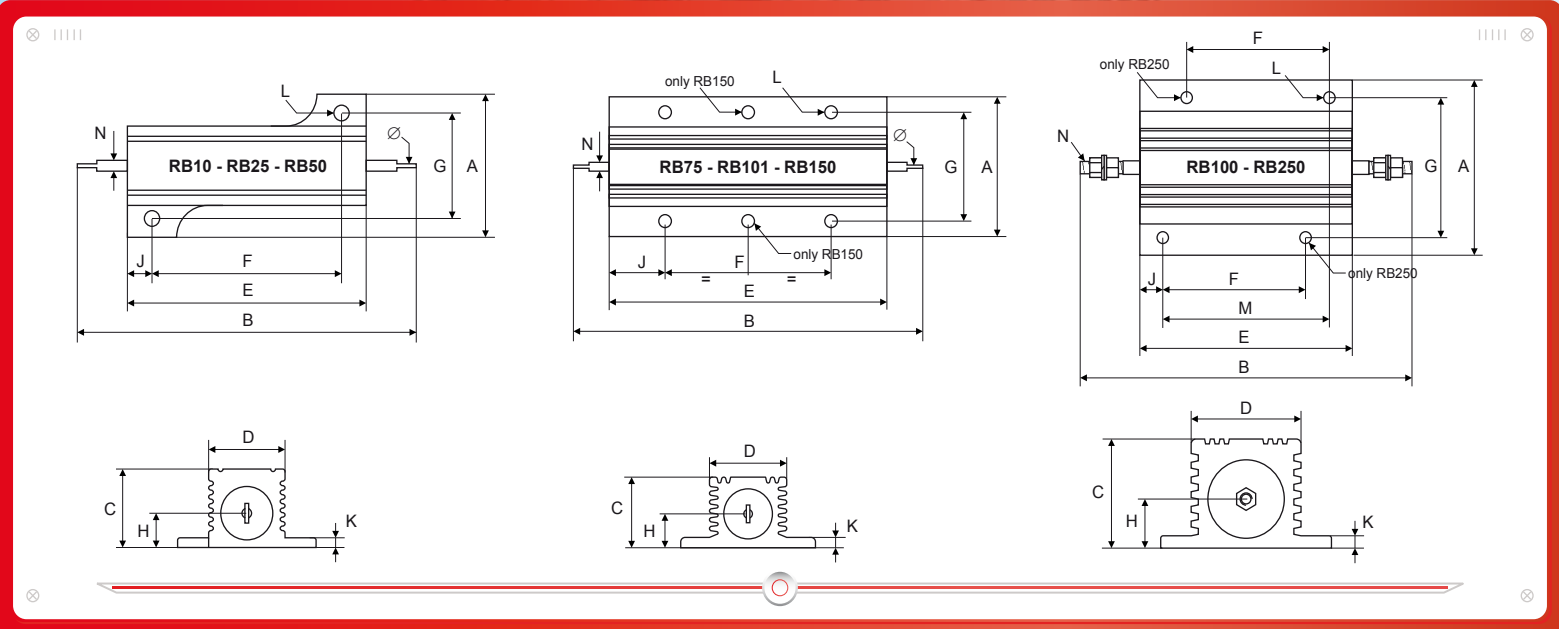
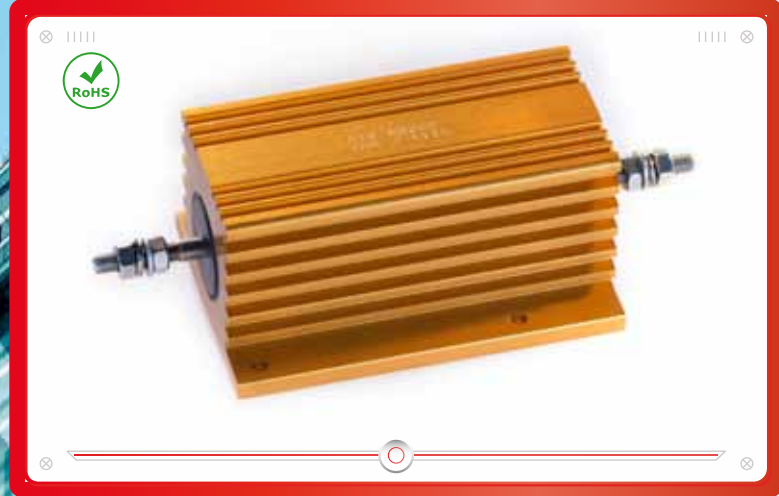
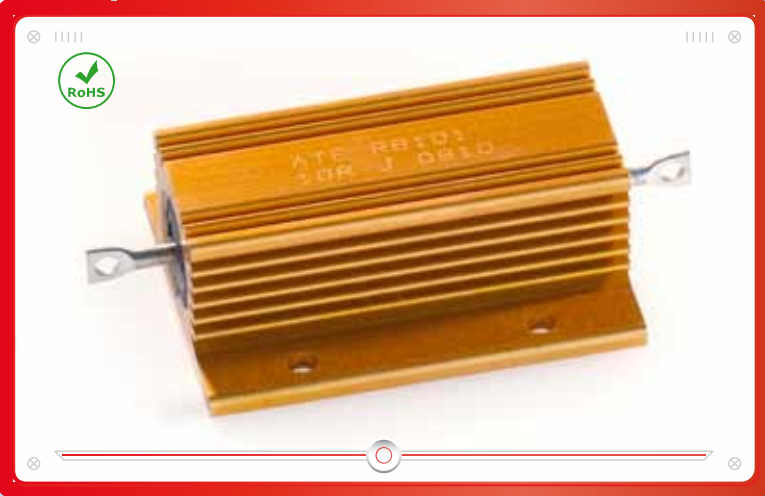

ATE Type	Dimensions (mm)													
	A	B	C	D	E	F	G	H	J	K	L	M	N	Ø
RB10	20.4	35	10	11	19	14.3	15.9	5	2.4	2	2.4	-	2	2.2
RB25	27.2	49	14	14	27	18.3	19.8	6.5	4.4	2	3.2	-	2	2.2
RB50	29.2	71	16	16	50	39.7	21.5	7	5.2	2	3.2	-	2	2.2
RB75	47	73	24	27	48	29	37	11.5	9.5	3.5	4.4	-	3	3.2
RB101	47	89	24	27	64	35	37	11.5	14.5	3.5	4.4	-	3	3.2
RB150	47	122	24	27	97	58	37	11.5	19.5	3.5	4.4	-	3	3.2
RB100	71.5	139	44.5	46	89	-	57.1	20	9.6	5	4.8	69.8	M5	-
RB250	76	178	55.6	54	114	76.2	63.5	25.5	7.8	6.3	4.8	98.4	M6	-
Tol.	±0.2	±1	±0.2	±0.2	±0.5	±0.2	±0.2	±0.2	±0.5	±0.2	±0.2	±0.2	±0.2	±0.2

RB - MASSIMA POTENZA VS. TEMPERATURA DISSIPATORE

RB - DERATING CURVES

RB10 - Derating

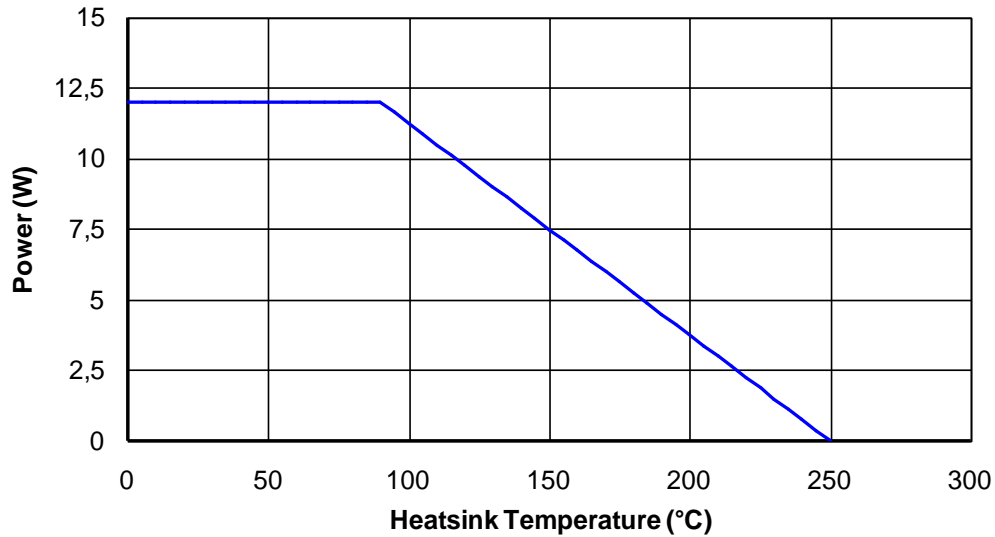

Heatsink dimensions: 415cm² x 1mm

RB25 - Derating

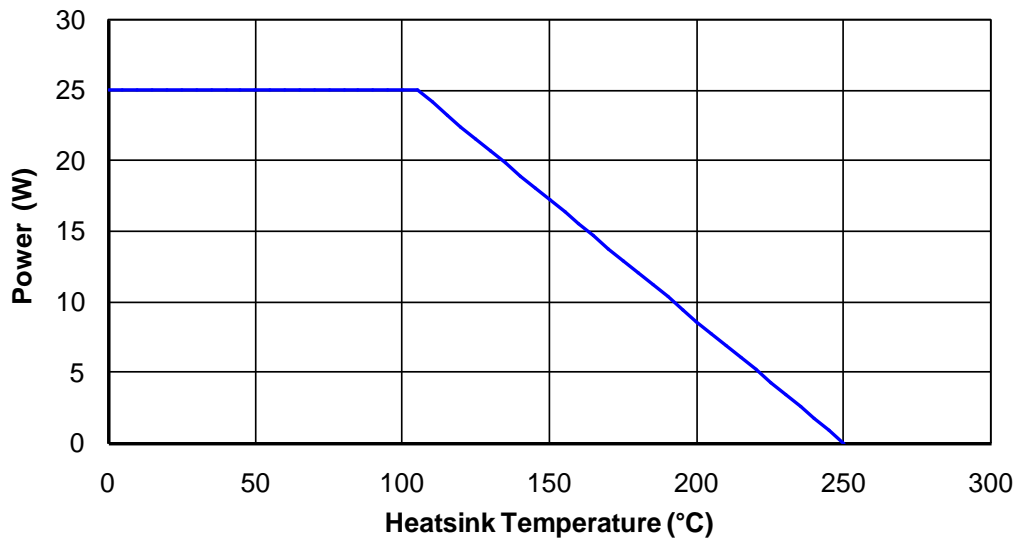

Heatsink dimensions: 535cm² x 1mm

- The use of heat conductive grease / paste is recommended between the resistor case and heatsink.
- Further derating has to be applied for reduced heatsink / chassis area.

RB - MASSIMA POTENZA VS. TEMPERATURA DISSIPATORE

RB - DERATING CURVES

RB50 - Derating

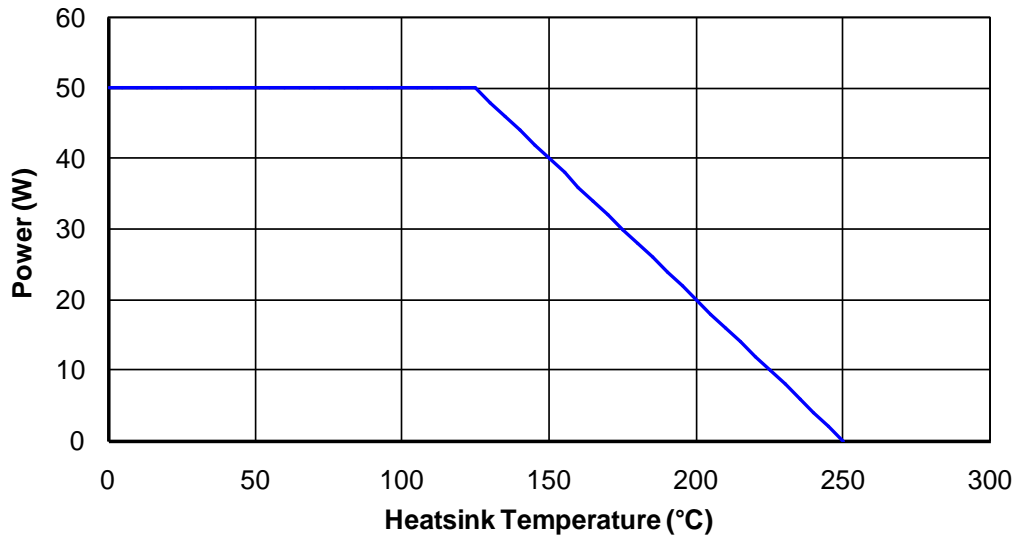

Heatsink dimensions: 930cm² x 1,5mm

RB75 - Derating

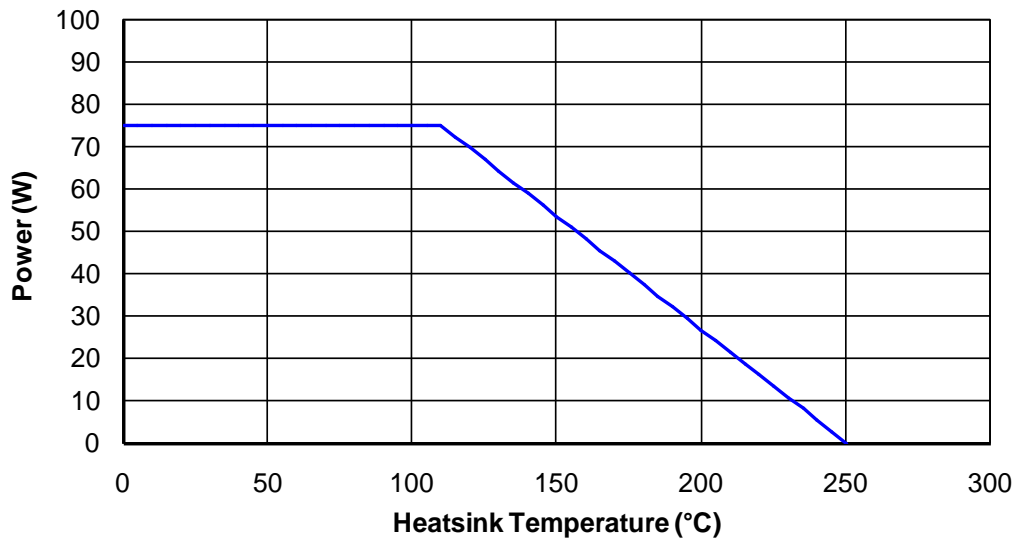

Heatsink dimensions: 995cm² x 3mm

- The use of heat conductive grease / paste is recommended between the resistor case and heatsink.
- Further derating has to be applied for reduced heatsink / chassis area.

RB - MASSIMA POTENZA VS. TEMPERATURA DISSIPATORE
RB - DERATING CURVES

RB101 - Derating

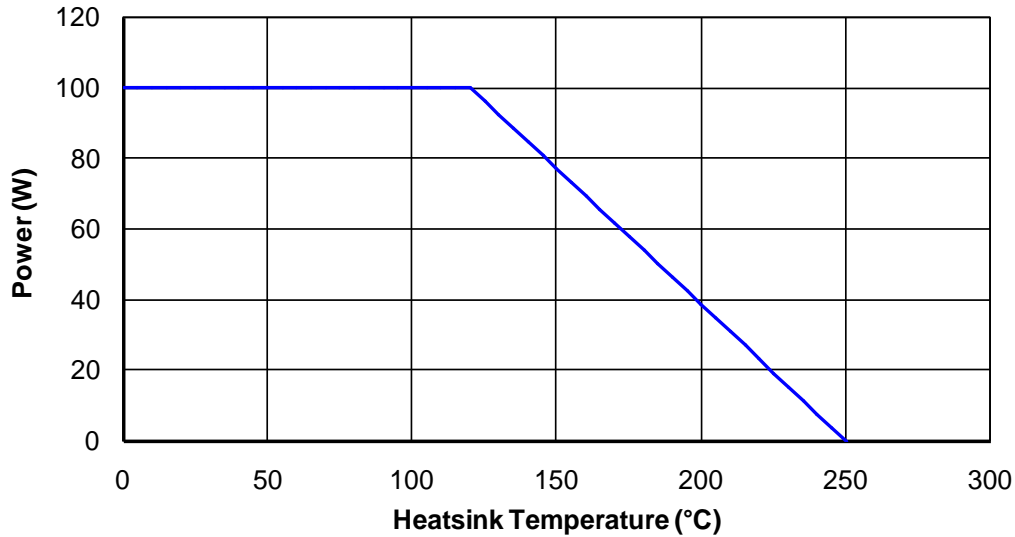

Heatsink dimensions: 995cm² x 3mm

RB150 - Derating

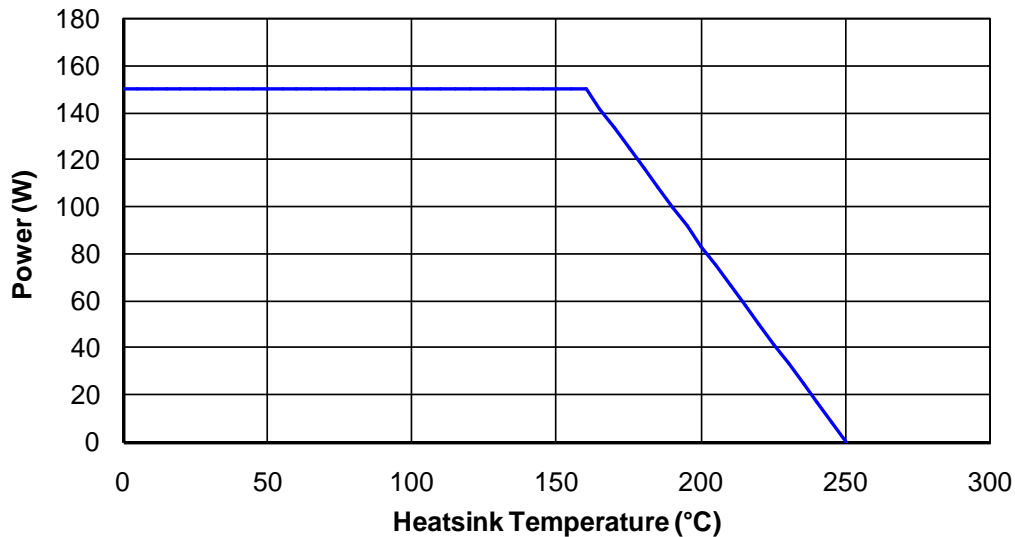

Heatsink dimensions: 995cm² x 3mm

- The use of heat conductive grease / paste is recommended between the resistor case and heatsink.
- Further derating has to be applied for reduced heatsink / chassis area.

RB - MASSIMA POTENZA VS. TEMPERATURA DISSIPATORE

RB - DERATING CURVES

RB100 - Derating

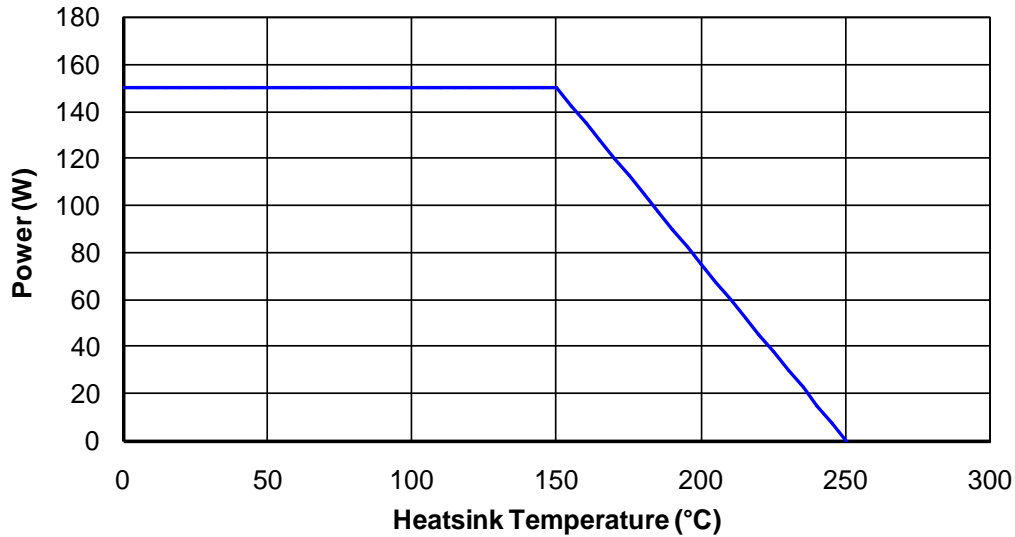

Heatsink dimensions: 930cm² x 3mm

RB250 - Derating

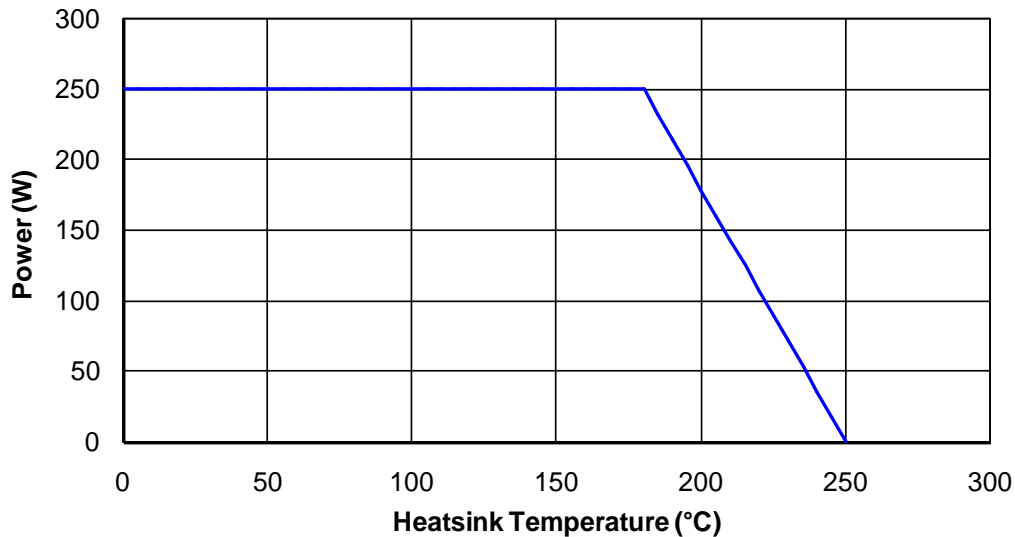

Heatsink dimensions: 930cm² x 3mm

- The use of heat conductive grease / paste is recommended between the resistor case and heatsink.
- Further derating has to be applied for reduced heatsink / chassis area.

CARICHI IMPULSIVI PER RESISTORI CS E RB
PULSE LOAD CAPABILITY FOR CS AND RB RESISTORS
 $1s \leq t \leq 1000s$

RESISTORI CS / CS RESISTORS

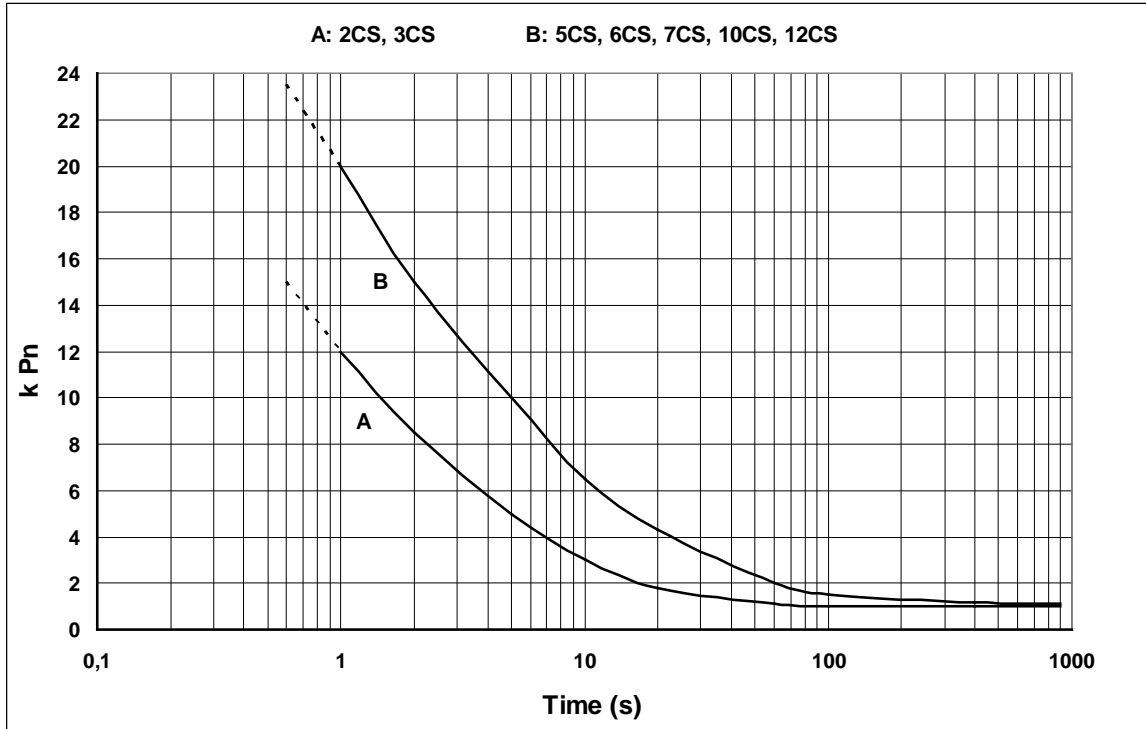

RESISTORI RB / RB RESISTORS

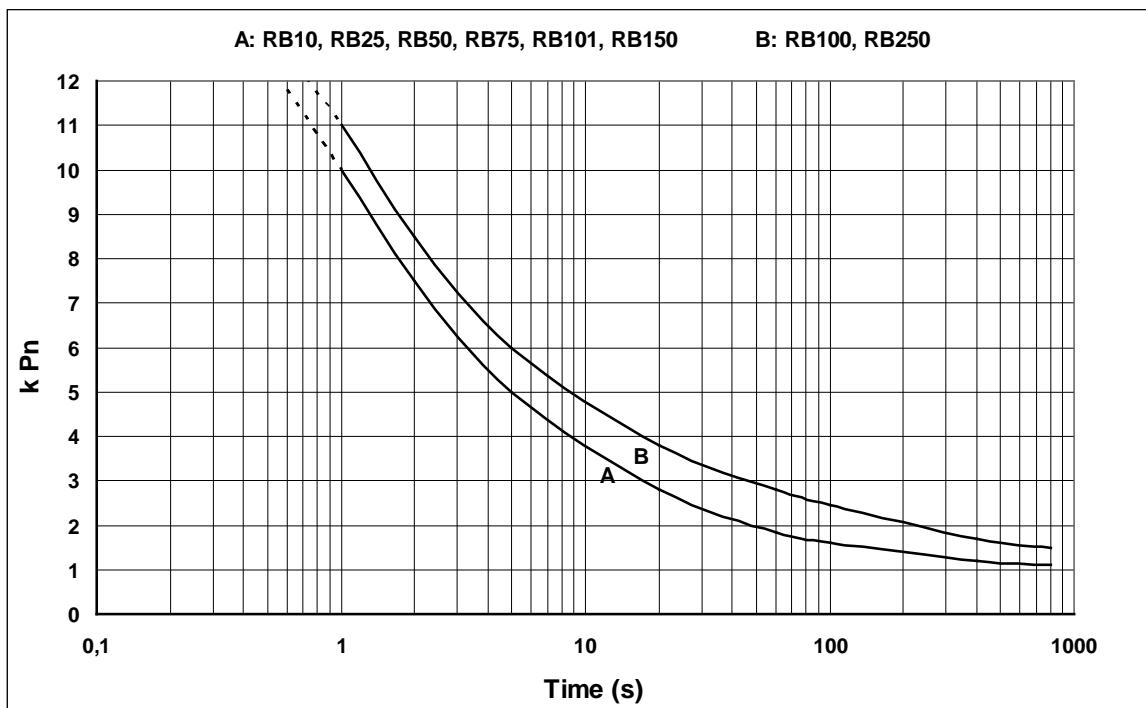

CARICHI IMPULSIVI PER RESISTORI CS E RB PULSE ENERGY FOR CS AND RB RESISTORS $10^{-6}s \leq t \leq 1s$

RESISTORI RB / RB RESISTORS

Per valutare l'energia massima che un resistore RB può sopportare per tempi compresi tra $10^{-6}s$ e $1s$ occorre tracciare una retta tra l'energia adiabatica tipica per ogni valore ohmico (UT23, [punti ●]) e l'energia corrispondente a $1s$ (10Pn, [punti ■]).

In figura è riportato l'esempio per il valore 10Ω .

To value maximum load capability of a RB resistor, for application between $10^{-6}s$ and $1s$, you have to draw a line that starts with the adiabatic energy of your ohmic value (UT23, [points ●]) and ends with the energy load for $1s$ (10Pn, [points ■]).

The graph shows the 10Ω example.

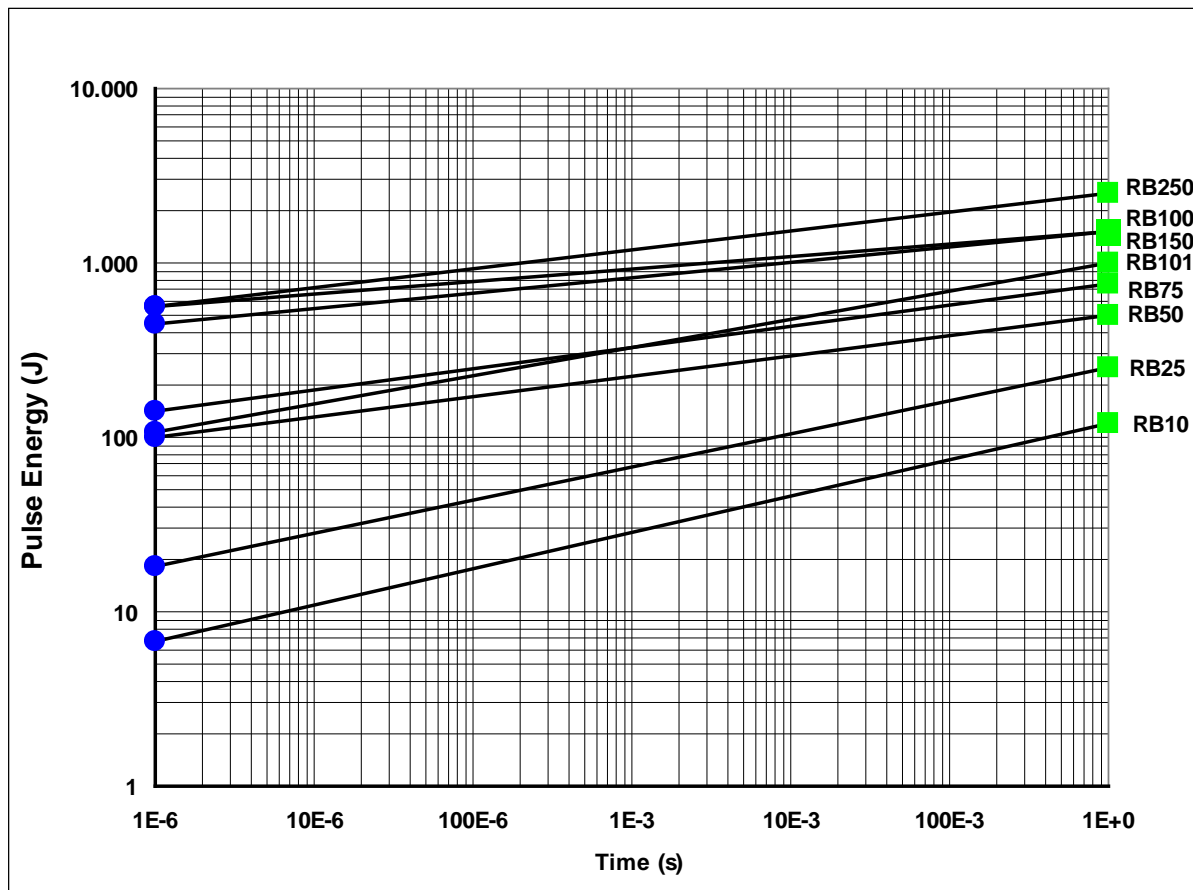

Il grafico è valido per i resistori standard; per avvolgimenti particolari e antinduttivi, o per impulsi ripetuti nel tempo, consultare il supporto tecnico ATE Electronics.

The graph is valid for standard resistors; for special applications and non inductive winding, or for repetitive pulses, ask to the ATE Electronics technical support.

ATE Electronics

Via Scaletta 13, IT10094 Giaveno, Italy

+39 (0) 11 9378575

+39 (0) 11 9376463

✉ info@ate-electronics.com

www.ate-electronics.com

Page 2 of 2

DATI TERMICI PER RESISTORI CS E RB
THERMAL DATA FOR CS AND RB RESISTOR

Resistore Resistor	Potenza max. Maximum Power (W)	Temp. sup. Hot spot (°C), amb.=25°C	Temperatura filo Wire temp. (°C), amb.=25°C	Costante tempo Time constant (s)	Aumento Temp. Temperature rise (°C/W)
RESISTORI CS CS RESISTOR					
2CS	3	300	320	60	91
3CS	4	320	340	70	74
5CS	6	340	370	100	52
6CS	7	340	370	100	45
7CS	10	330	370	160	30
10CS	13	340	380	180	24
12CS	15	350	390	200	21
RESISTORI RB, SU PANNELLO STANDARD RB RESISTOR ON STANDARD HEATSINK					
RB10	12	80	200	240	5,1
RB25	25	100	260	300	3,0
RB50	50	120	225	360	1,9
RB75	75	115	300	1080	1,1
RB101	100	140	290	1320	1,0
RB150	150	170	325	1080	1,0
RB100	150	150	250	1200	0,84
RB250	250	190	300	1560	0,66
RESISTORI RB, SENZA PANNELLO RB RESISTOR WITHOUT HEATSINK					
RB10	6	195	250	360	28
RB25	12,5	210	300	420	15
RB50	20	220	290	600	10
RB75	35	195	300	720	5,0
RB101	40	185	280	720	4,0
RB150	55	190	265	720	3,0
RB100	75	190	235	1680	2,2
RB250	100	165	210	1800	1,4

RESISTORI RB: RISCALDAMENTO IN FUNZIONE DEL TEMPO

RB RESISTORS: HEATING VERSUS TIME

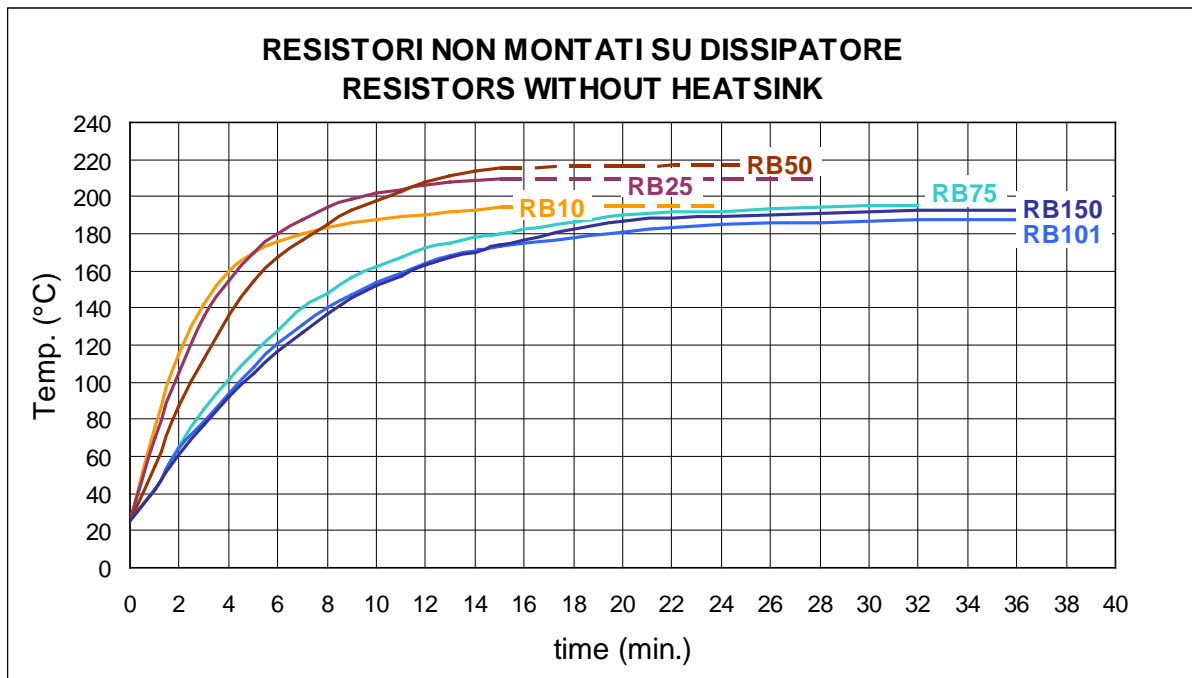
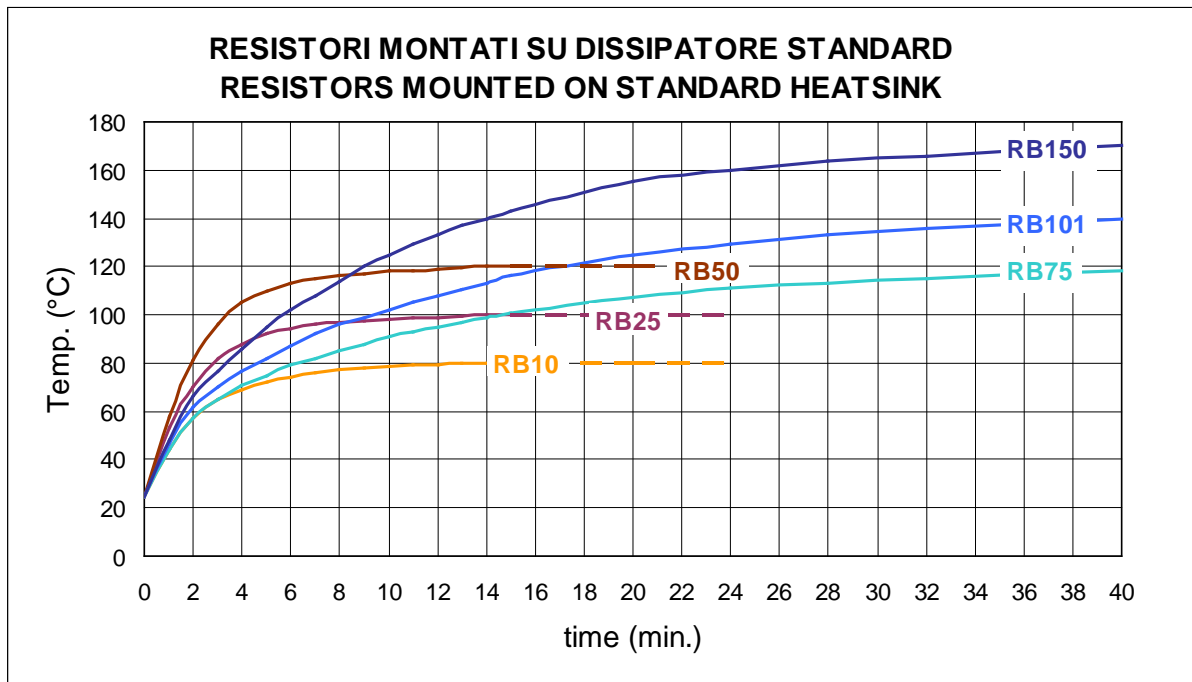

RESISTORI RB: RISCALDAMENTO IN FUNZIONE DEL TEMPO

RB RESISTORS: HEATING VERSUS TIME

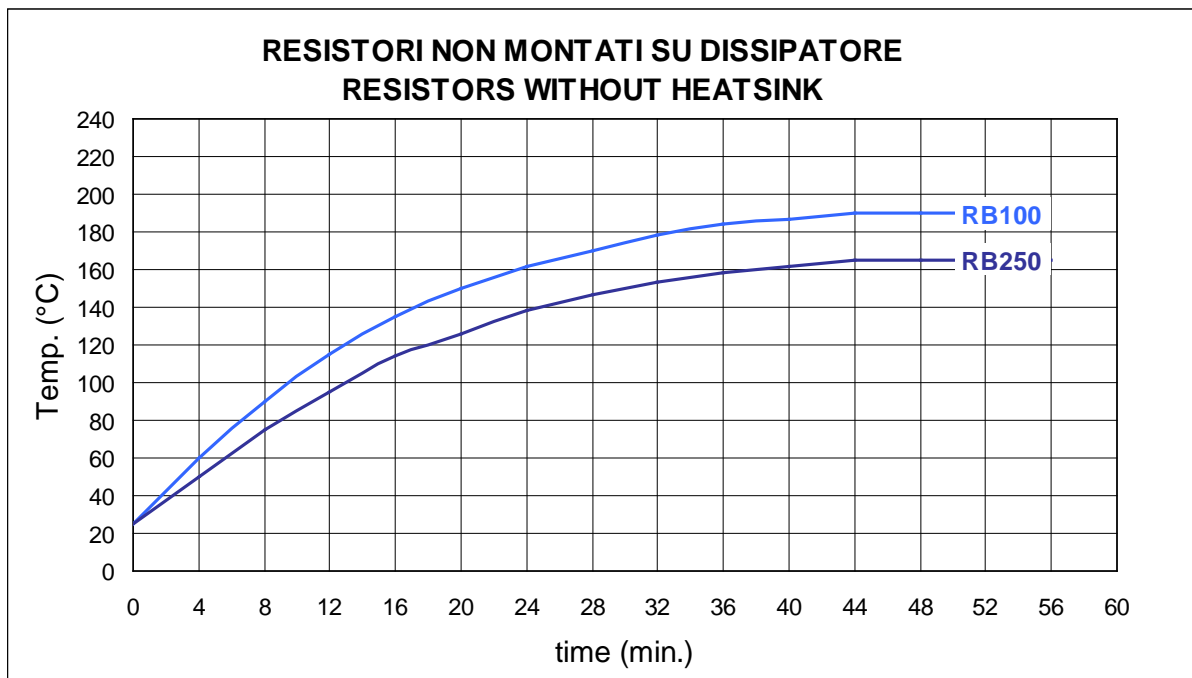
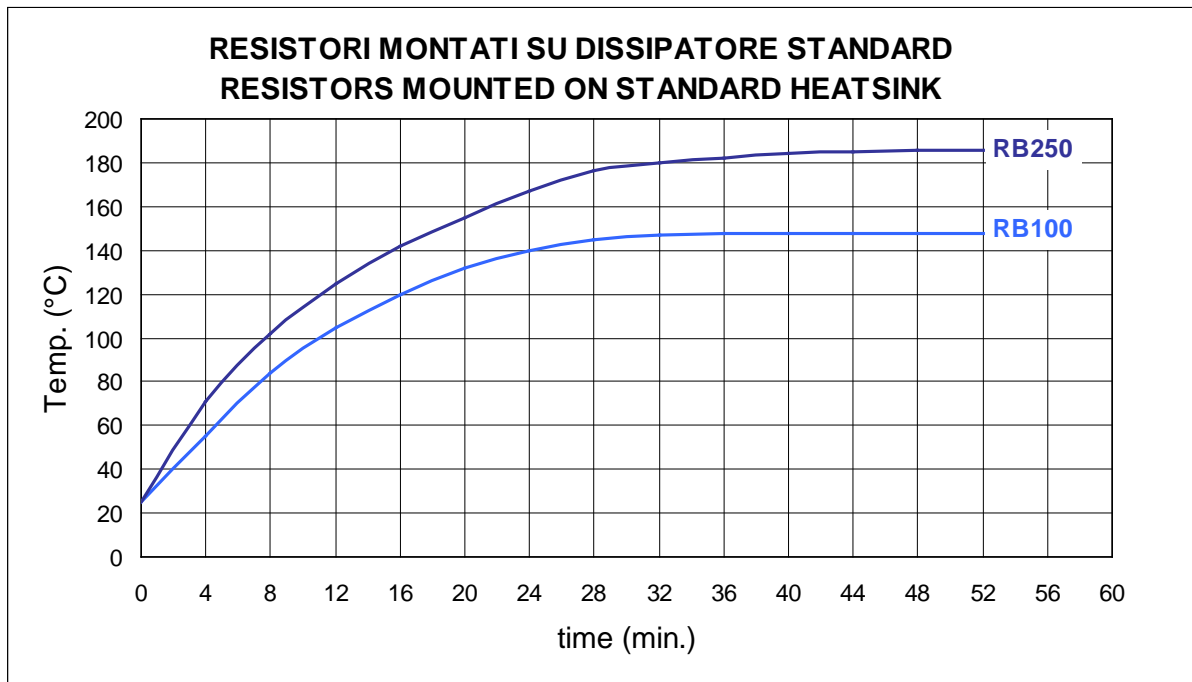

RB - VALORI INDUTTANZA PARASSITA
RB - PARASITIC INDUCTANCE VALUES

Type Value Ω	RB10	RBN10	RB25	RBN25	RB50	RBN50	RB75	RBN75	RB101	RBN101	RB150	RBN150	RB100	RBN100	RB250	RBN250
R01	0,027	0,023	0,032	0,027	0,037	0,032										
R022	0,028	0,023	0,032	0,029	0,039	0,032										
R033	0,030	0,024	0,033	0,030	0,040	0,032										
R047	0,033	0,025	0,039	0,032	0,042	0,035										
R068	0,038	0,027	0,042	0,033	0,048	0,037										
R10	0,041	0,030	0,050	0,036	0,057	0,040	0,070	0,040	0,062	0,043	0,073	0,044	0,072	0,030	0,061	0,032
R22	0,051	0,031	0,071	0,039	0,086	0,043	0,094	0,045	0,120	0,058	0,123	0,060	0,130	0,041	0,110	0,041
R33	0,060	0,034	0,089	0,042	0,120	0,049	0,115	0,054	0,170	0,063	0,21	0,066	0,180	0,049	0,158	0,048
R47	0,075	0,038	0,132	0,047	0,173	0,057	0,168	0,065	0,20	0,071	0,27	0,072	0,30	0,065	0,26	0,062
R68	0,089	0,039	0,158	0,051	0,23	0,061	0,25	0,071	0,25	0,083	0,50	0,087	0,40	0,082	0,34	0,074
1R0	0,107	0,049	0,21	0,055	0,31	0,070	0,40	0,081	0,28	0,095	0,51	0,100	0,55	0,110	0,49	0,097
2R2	0,148	0,055	0,31	0,066	0,55	0,089	0,41	0,105	0,49	0,129	0,71	0,152	1,07	0,180	0,82	0,130
3R3	0,193	0,068	0,41	0,074	0,79	0,102	1,19	0,125	0,70	0,151	1,03	0,195	1,50	0,27	1,51	0,180
4R7	0,26	0,080	0,58	0,089	1,12	0,131	1,41	0,140	1,83	0,20	1,51	0,25	2,3	0,32	2,2	0,24
6R8	0,32	0,082	0,72	0,100	1,50	0,148	2,1	0,161	2,5	0,24	1,55	0,30	3,1	0,53	2,9	0,32
10R	0,43	0,138	0,90	0,120	2,0	0,190	3,4	0,20	4,4	0,30	4,5	0,37	4,3	0,76	4,1	0,43
22R	0,79	0,20	1,40	0,20	3,4	0,20	4,1	0,27	7,5	0,38	7,9	0,51	8,1	1,30	7,8	0,63
33R	1,20	0,32	1,90	0,30	4,9	0,32	5,6	0,36	8,4	0,44	11,4	0,78	11,0	1,97	12,0	0,85
47R	1,98		2,6	0,42	7,4	0,45	9,4	0,50	11,8	0,57	11,5	1,30	15,0	3,0	18,0	1,20
68R	2,8		3,3	0,58	9,8	0,56	12,5	0,76	12,0	1,2	18,4	2,5	24	4,0	24	1,50
100R	4,8		4,3		12,0	0,65	13,6		17,4		20		33	5,2	32	1 pF
2K5	1 pF	1 pF		0,5 pF	1 pF	4 pF							8 pF	4 pF	18 pF	3 pF
5K0	1 pF	1 pF	0,5 pF	2 pF	3,8 pF	6 pF							10 pF	10 pF	20 pF	20 pF
10K			2 pF	2 pF	4,9 pF	6 pF							12 pF	12 pF	20 pF	20 pF
20K			2 pF	2 pF	5,2 pF	6 pF							12 pF	12 pF		

Tutti i valori in tabella sono espressi in μH (10^{-6} Henry).
Possono verificarsi variazioni di circa il 30% sui valori indicati a causa di variazioni della resistività del filo.
Strumento di misura: Q Meter HP 4342A, frequenze: 7.96MHz & 25.15MHz

All the above values are expressed in μH (10^{-6} Henry).
Variation of about 30% can be expected from the indicated values due to variation of the wire resistivity.
Measurement System: Q Meter HP 4342A, frequencies: 7.96MHz & 25.15MHz

ATE Electronics

Via Scaletta 13, IT10094 Giaveno, Italy

+39 (0) 11 9378575

+39 (0) 11 9376463

✉ info@ate-electronics.com

www.ate-electronics.com

RB SERIES - ENERGY CAPABILITY

E _{ad} (Joule)								
MODEL VALUE Ω	RB10	RB25	RB50	RB75	RB101	RB100	RB150	RB250
0,01	25.1	72,9	245	-	-	-	-	-
0,015	21.2	54,4	171	-	-	-	-	-
0,022	19.9	55,5	160	-	-	-	-	-
0,033	30.0	29,8	120	-	-	-	-	-
0,047	16.6	23,9	85,9	-	-	-	-	-
0,068	15.4	34,5	96,3	-	-	-	-	-
0,1	15,7	50,9	203	141	252	377	362	731
0,15	15,1	53,3	136	94,6	76,4	549	378	1094
0,22	12,4	34,5	112	88,9	311	806	354	1603
0,33	8,30	33,1	117	168	208	833	467	603
0,47	21,2	26,5	106	106	190	666	426	859
0,68	17,9	17,3	154	-	154	617	429	1096
1	18,5	45,1	100	157	127	907	354	907
1,5	15,1	39,6	84,7	84,5	157	763	340	1361
2,2	9,90	40,7	55,8	55,6	124	891	280	1120
3,3	9,27	33,3	148	149	83,6	748	186	748
4,7	8,65	32,2	124	124	340	598	265	1065
6,8	7,86	30,8	125	125	306	1068	172	864
10	6,76	18,4	100	142	107	564	451	564
15	7,55	18,4	67,9	102	213	380	396	846
22	7,22	14,9	62,1	99,5	151	993	406	557
33	6,02	16,5	60,9	60,9	138	872	332	1489
47	6,36	19,9	54,2	54,2	132	670	212	1241
68	4,47	16,8	60,5	60,5	78,6	685	307	969
100	4,30	13,4	50,3	36,6	95,2	452	184	686
150	3,96	14,2	55,0	54,8	101	422	133	678
220	3,44	15,4	54,3	40,5	71,9	406	210	620
330	2,75	8,60	44,0	31,1	81,8	293	121	609
470	2,75	7,22	44,4	44,3	62,9	318	153	418
680	1,72	5,68	43,5	28,7	64,3	249	125	460
1,0k	1,72	5,85	26,3	42,3	42,3	248	94,6	326
1,5k	1,38	6,02	23,2	39,5	39,5	200	63,4	372
2,2k	1,55	3,61	25,1	18,4	58,1	208	93,2	294
3,3k	1,20	5,50	19,2	13,2	27,5	139	51,0	312
4,7k	1,20	2,41	12,2	12,0	27,1	124	54,1	199
6,8k	1,20	3,61	11,1	11,1	27,3	105	39,3	179
10k	1,03	2,58	16,5	16,5	26,4	83,5	40,2	155
15k	1,55	2,41	10,8	7,74	14,4	87,2	38,7	125
22k	-	2,24	8,08	7,91	16,8	86,4	36,2	88,7
33k	-	3,44	8,26	5,50	14,1	85,3	23,7	133
47k	-	-	7,74	7,74	11,7	77,7	24,6	121
68k	-	-	7,05	-	11,1	-	17,2	-
100k	-	-	10,3	-	-	52,2	16,5	52,3

Based on adiabatic formula $E_{ad} = m \times \Delta T \times C$,

where $\Delta T = 400^{\circ}\text{C}$; m = weight of wire; C = specific heat

MSDS

RB25 / RBN25

		%	Peso tot (g)	Peso (g)	
Ceramic core:	Steatite		1.24		
	63210-56-0	100.0%		1.24	
End caps:	Stainless steel 304		0.28		
	7439-89-6	68.5%		0.19	
	7440-47-3	19.0%		0.05	
	7440-02-0	10.5%		0.03	
	7439-96-5	2.0%		0.01	
Aluminium case:	Aluminium		9.38		
	7429-90-5	100.0%		9.38	
Terminals:	Tinned copperweld		0.58		
	7439-89-6	75.0%		0.44	
	7440-50-8	24.0%		0.14	
	7440-02-0	0.2%		0.00	
	7440-31-5	0.8%		0.00	
Insulation:	Epoxy resin		2.20		
	9003-35-4	7.0%		0.15	
	14808-60-7	35.0%		0.77	
	60676-86-0	25.0%		0.55	
Resistive wire:	CuNi44 -- R01 < R < 33R		-		
	7440-50-8	56.0%			
	7440-02-0	44.0%			
	NiCr20Al -- 39R < R < Rmax		-		
	7440-02-0	74.5%			
	7440-47-3	20.0%			
	7429-90-5	3.5%			
	7440-21-3	1.0%			
	7439-96-5	0.5%			
	7439-89-6	0.5%			
	Wire protection:	Silicon coating		0.10	
		Alkyl silicone resins	36.0%		0.04
		12001-26-2	46.0%		0.05
		1332-58-7	18.0%		0.02

RB50 / RBN50

		%	Peso tot (g)	Peso (g)
Ceramic core:	Steatite		6.48	
	63210-56-0	100.0%		6.48
End caps:	Stainless steel 304		0.58	
	7439-89-6	68.5%		0.40
	7440-47-3	19.0%		0.11
	7440-02-0	10.5%		0.06
	7439-96-5	2.0%		0.01
Aluminium case:	Aluminium		21.00	
	7429-90-5	100.0%		21.00
Terminals:	Tinned copperweld		0.58	
	7439-89-6	75.0%		0.44
	7440-50-8	24.0%		0.14
	7440-02-0	0.2%		0.00
	7440-31-5	0.8%		0.00
Insulation:	Epoxy resin		3.60	
	9003-35-4	7.0%		0.25
	14808-60-7	35.0%		1.26
	60676-86-0	25.0%		0.90
Resistive wire:	CuNi44 -- R01 < R < 150R		-	
	7440-50-8	56.0%		
	7440-02-0	44.0%		
	NiCr20Al -- 180R < R < Rmax		-	
	7440-02-0	74.5%		
	7440-47-3	20.0%		
	7429-90-5	3.5%		
	7440-21-3	1.0%		
	7439-96-5	0.5%		
	7439-89-6	0.5%		
Wire protection:	Silicon coating		0.18	
	Alkyl silicone resins	36.0%		0.06
	12001-26-2	46.0%		0.08
	1332-58-7	18.0%		0.03

MSDS

RB101

		%	Peso tot (g)	Peso (g)	
Ceramic core:	Steatite		16.10		
	63210-56-0	100.0%		16.10	
End caps:	Stainless steel 304		1.86		
	7439-89-6	68.5%		1.27	
	7440-47-3	19.0%		0.35	
	7440-02-0	10.5%		0.20	
	7439-96-5	2.0%		0.04	
Aluminium case:	Aluminium		71.20		
	7429-90-5	100.0%		71.20	
Terminals:	Tinned iron		1.50		
	7439-89-6	99.0%		1.49	
	7439-96-5	0.3%		0.00	
	7440-02-0	0.1%		0.00	
	7440-31-5	0.6%		0.01	
Insulation:	Epoxy resin		15.05		
	9003-35-4	7.0%		1.05	
	14808-60-7	35.0%		5.27	
	60676-86-0	25.0%		3.76	
Resistive wire:	CuNi44 -- R10 < R < 180R		-		
	7440-50-8	56.0%			
	7440-02-0	44.0%			
	NiCr20Al -- 200R < R < Rmax		-		
	7440-02-0	74.5%			
	7440-47-3	20.0%			
	7429-90-5	3.5%			
	7440-21-3	1.0%			
	7439-96-5	0.5%			
	7439-89-6	0.5%			
	Wire protection:	Silicon coating		0.44	
		Alkyl silicone resins	36.0%		0.16
		12001-26-2	46.0%		0.20
		1332-58-7	18.0%		0.08



Maximum pulse voltage 1,2/50µsec. (non repetitive)

Axial wire wound resistors CS											
Type	2kV	3kV	4kV	5kV	6kV	7kV	8kV	9kV	10kV	11kV	12kV
2CS	≥22R	≥100R	≥220R	≥470R	≥1K2	-	-	-	-	-	-
3CS	≥15R	≥68R	≥120R	≥390R	≥680R	≥1K5	-	-	-	-	-
5CS	≥4R7	≥22R	≥33R	≥47R	≥82R	≥150R	≥220R	≥330R	≥1K0	-	-
6CS	≥3R3	≥10R	≥22R	≥39R	≥68R	≥100R	≥150R	≥220R	≥330R	≥560R	≥820R
7CS	≥1R5	≥3R3	≥6R8R	≥10R	≥22R	≥33R	≥47R	≥68R	≥100R	≥150R	≥220R
10CS	≥1R2	≥2R7	≥3R9	≥6R8	≥10R	≥22R	≥33R	≥47R	≥68R	≥82R	≥100R
12CS	≥1R0	≥2R7	≥3R3	≥5R6	≥8R2	≥15R	≥22R	≥33R	≥47R	≥68R	≥82R

Power wire wound resistors aluminium housed RB											
Type	2kV	3kV	4kV	5kV	6kV	7kV	8kV	9kV	10kV	11kV	12kV
RB10	≥15R	≥68R	≥120R	≥390R	≥680R	≥1K5	-	-	-	-	-
RB25	≥4R7	≥22R	≥33R	≥47R	≥82R	≥150R	≥220R	≥330R	≥1K0	-	-
RB50	≥1R2	≥2R7	≥3R9	≥6R8	≥10R	≥22R	≥33R	≥47R	≥68R	≥82R	≥100R

Note 1 : The table is effective only for standard resistors, for non inductive applications corresponding resistors are CSNC and RBNC

Note 2 : Voltage limit is based on 800V/mm (winding length).