

REVISION RECORD				
REV	ECN	DESCRIPTION	DRFT	DATE

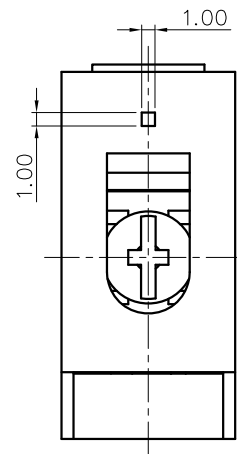

NOTES1:
 UL Standard
 1.Rated Voltage/Current : 600V / 30A
 2.Torque Value : M4 , 10.53Lb.in
 3.Wire Range : 20~12AWG(SOL),18~12AWG(STR)
 IEC Standard
 1.Rated Voltage/Current : 450V / 32A
 2.Torque Value : M4 , 1.2N·m
 3.Wire Range : 0.5~4mm²

NOTES2:
 1.Dimension shall be interpreted per ASME Y14.5-2009
 2.Poles : N=01P
 3.Stripping length : 8~10mm
 4.Withstanding Voltage : AC2500V/1Min.
 5.Operating temperature: -40°C~+105°C
 6.Undimensioned Tolerances:

Pitch range in mm			Nominal dimension range in mm					-	∩	∇
TO	Over TO	TO	TO	Over TO	Over TO	Over TO	Over TO	0.1/10		
6	6 TO 10	10 TO 24	30	30 TO 60	60 TO 100	100 TO 150	150			
	±0.15	±0.20	±0.30	±0.30	±0.50	±0.70	±1.00	±1.30	±2'	

7.RoHS Compliance

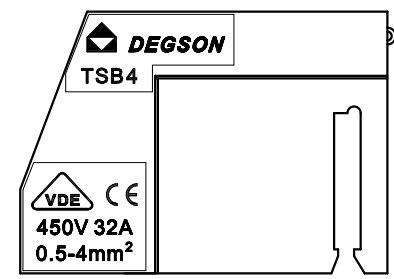
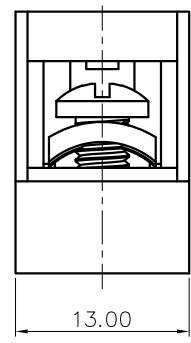
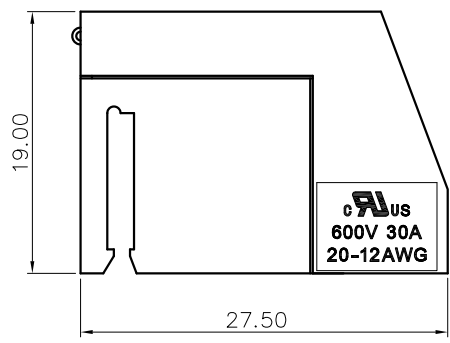

TSB 4 - 01P - 1Y - 00A (H)
 (Series No.) (Poles) (Single Pitch) (Color): 1.(Grey)
 2.(Blue)
 3.(Black)
 4.(Green)
 5.(Orange)
 6.(Red)
 7.(Transparent)
 8.(Yellow)
 9.(White)

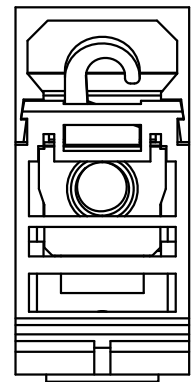

DETACHED LISTS	PART NO.:	NINGBO DEGSON ELECTRICAL CO., LTD			
	APPD:	NAME: TSB 4-01P-1Y-00A(H)			
	CHKD:	TITLE: CUSTOMER DRAWING			
	DRFT:	DRAWING NO.:		REV	DO
	THIRD ANGLE PROJECTION		MM (INCH)	DO NOT SCALE DRAWING	SCALE 1:1